

# Bovenbouw - Polycarbonaat

Patio cover without substructure - Polycarbonate  
Überdachung ohne Unterkonstruktion - Polycarbonat  
Superstructure - Polycarbonate

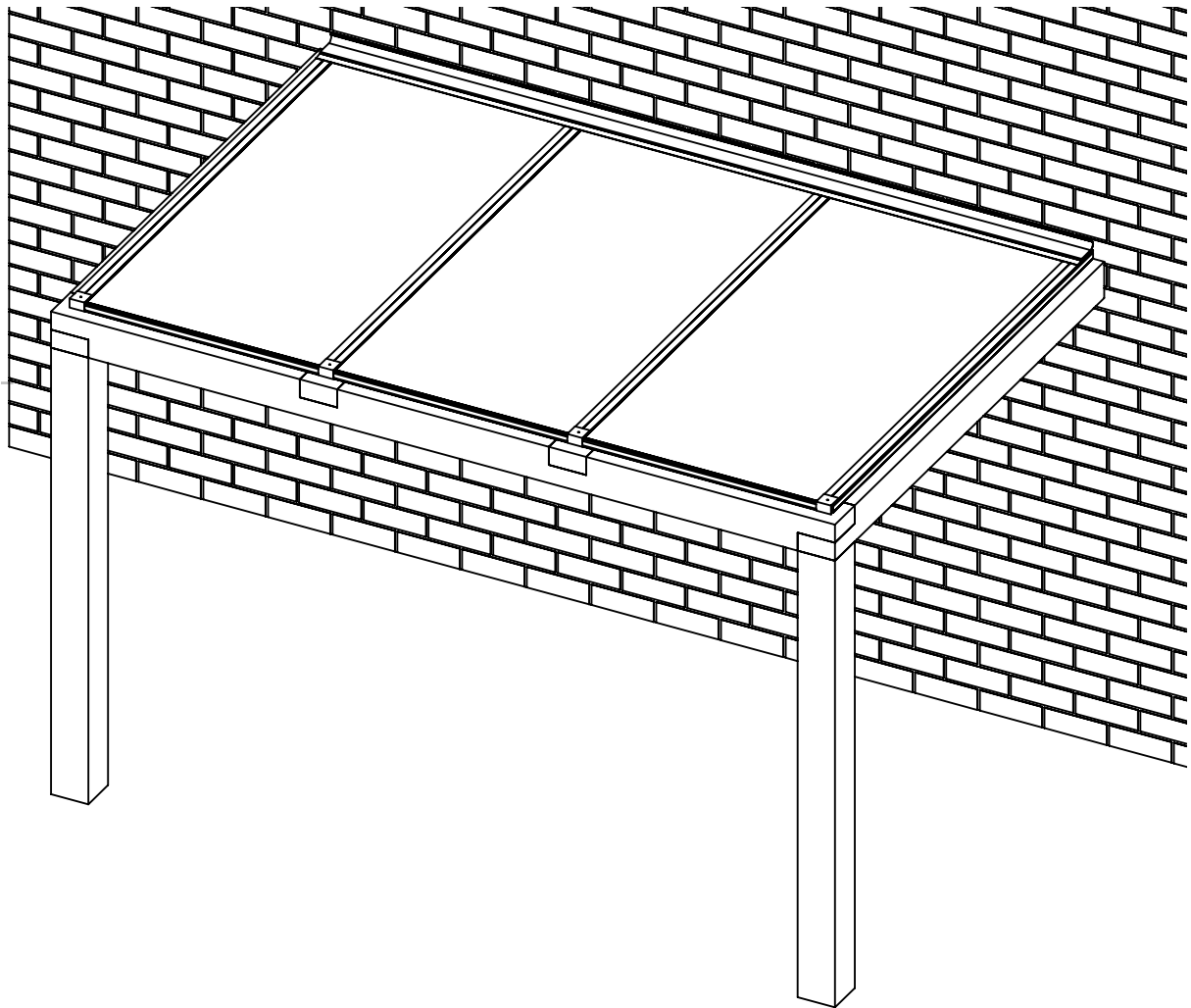

## Montagehandleiding

Assembly instructions  
Montageanleitung  
Notice de montage



# Inhoudsopgave

Contents | Inhaltsverzeichnis | Table de matières

<b>Randvoorwaarden</b> .....	<b>5</b>
Preconditions	
Voraussetzungen	
Conditions préalables	
<b>Onderdelen</b> .....	<b>7</b>
Parts	
Unterteile	
Pièces	
<b>Gereedschap</b> .....	<b>8</b>
Tools	
Werkzeuge	
Matériel nécessaire	
<b>Montage</b> .....	<b>9</b>
Assembly	
Montage	
Montage	



# Randvoorwaarden

Conditions préalables | Voraussetzungen | Preconditions

NL: **Veiligheid:** Werk altijd op een veilige manier. Bij glas altijd handschoenen en een veiligheidsbril gebruiken. Gebruik daarnaast werkschoenen ter bescherming van de voeten.

**Materiaal:** Gebruik alleen schroeven die worden meegeleverd, deze schroeven zijn geschikt voor zacht hout. Wanneer ander materiaal gebruikt wordt, dient zelf zorg voor geschikt bevestigingsmateriaal gedragen te worden.

**Check:** Controleer elk onderdeel voor montage op schade, was hiervoor het glas voor het plaatsen. Indien van toepassing, maak foto's van de schade en neem contact op met uw leverancier.

**Goot:** Plaats eventuele goot voor het aanbrengen van platen.

EN: **Safety:** Always work in a safe way. When working with glass, always use gloves and safety goggles. In addition, use work shoes to protect the feet.

**Material:** Only use screws that are supplied, these are suitable for soft wood. If other materials are used, you must provide your own suitable fastening material.

**Check:** Check each part for damage before assembly, wash the glass before fitting. If applicable, take photos of the damage and contact your supplier.

**Gutter:** Mount an optimal gutter before place the roofing sheets.

DU: **Sicherheit:** Arbeiten Sie immer in einer sicheren Weise. Verwenden Sie immer Handschuhe und Schutzbrillen für Glas. Verwenden

Sie außerdem Arbeitsschuhe, um die Füße zu schützen.

**Material:** Verwenden Sie für die Montage der Überbaus nur die gelieferten Schrauben. Diese Schrauben sind für weiches Holz geeignet. Wenn andere Materialien verwendet werden, müssen Sie selbst für geeignetes Befestigungsmaterial sorgen.

**Prüfung:** Prüfen Sie jedes Teil vor dem Zusammenbau auf Beschädigungen, waschen Sie das Glas vor dem Einbau. Falls zutreffend, fotografieren Sie den Schaden und kontaktieren Sie Ihren Lieferanten.

**Rinne:** Installieren Sie die Dachrinne vor dem Verlegen der Dachbahnen.

FR: **Sécurité:** Travaillez toujours de manière sûre. Avec du verre, utilisez toujours des gants et des lunettes de sécurité. De plus, utilisez des chaussures de travail pour protéger les pieds.

**Materiel:** N'utilisez que les vis fournies, ces vis sont adaptées au bois tendre. Si d'autres matériaux sont utilisés, vous devez fournir votre propre matériel de fixation approprié.

**Contrôle:** Vérifiez que chaque pièce n'est pas endommagée avant de l'assembler, et lavez le verre avant de le poser. Le cas échéant, prenez des photos des dommages et contactez votre fournisseur.

**Gouttière:** Installez une gouttière avant de poser les tôles de toiture.



# Onderdelen

Parts | Unterteile | Pièces

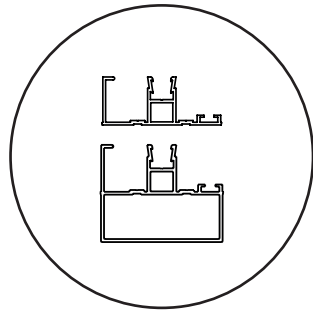

A15120 / A10191

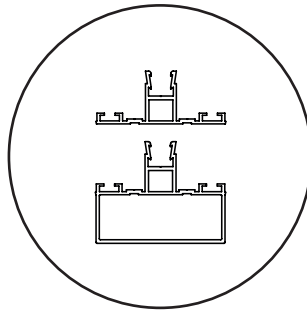

A15130 / A10176

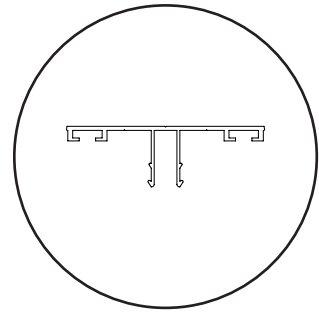

A10107

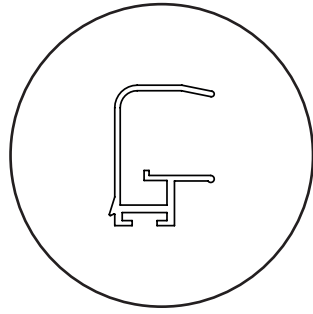

A10086

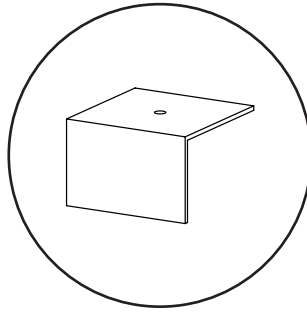

A10154

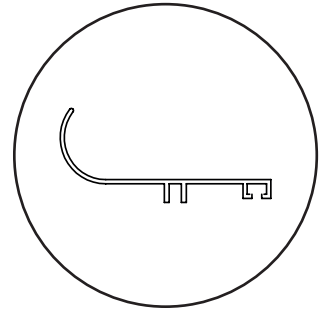

A15140

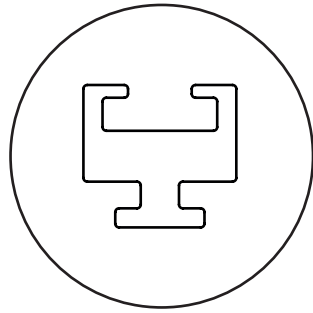

A10159

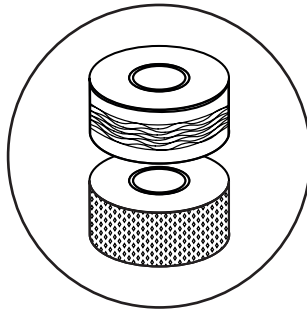

B21368

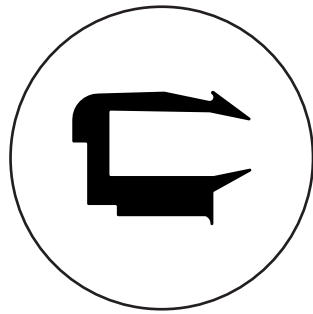
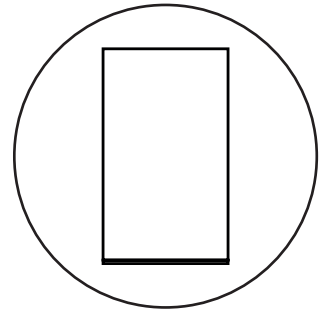

B20012

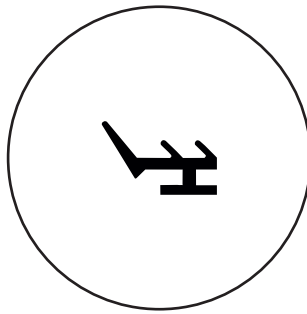

B21481

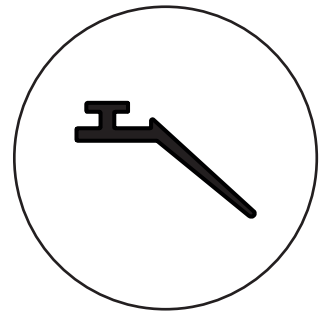

B21368

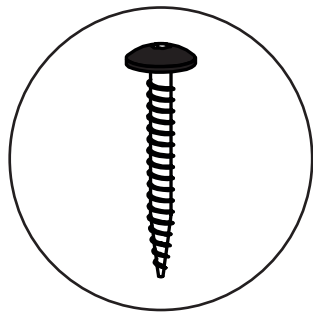

4,8x38

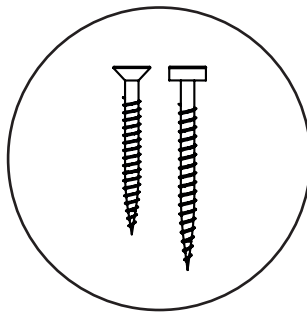

4,5x35 / 4,5x50

# Gereedschap

Tools | Werkzeuge | Matériel nécessaire

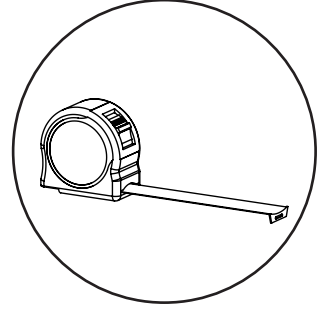
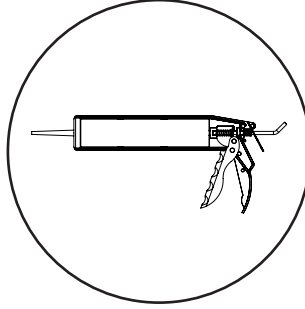
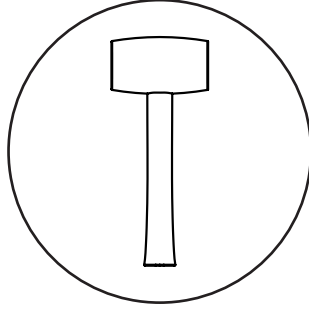
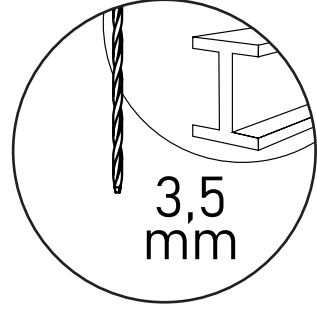
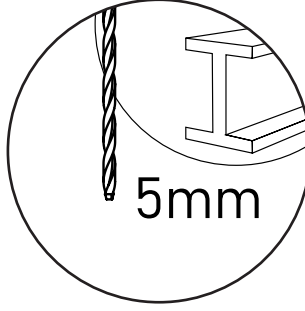
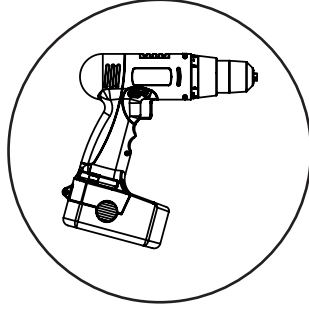
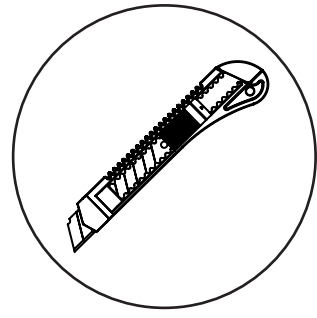
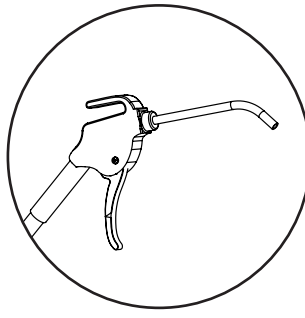
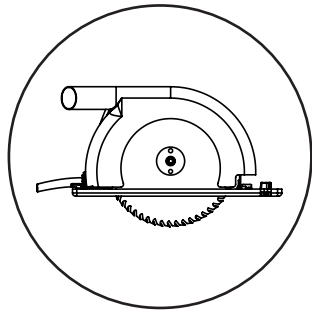



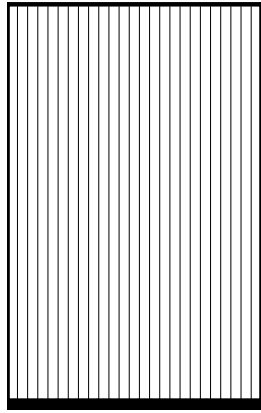

➔ step 1

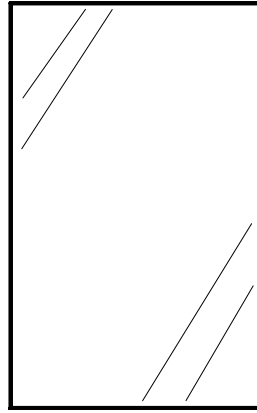

➔ step 6

# 1

\*Indien nodig  
If required  
Falls nötig  
Si nécessaire

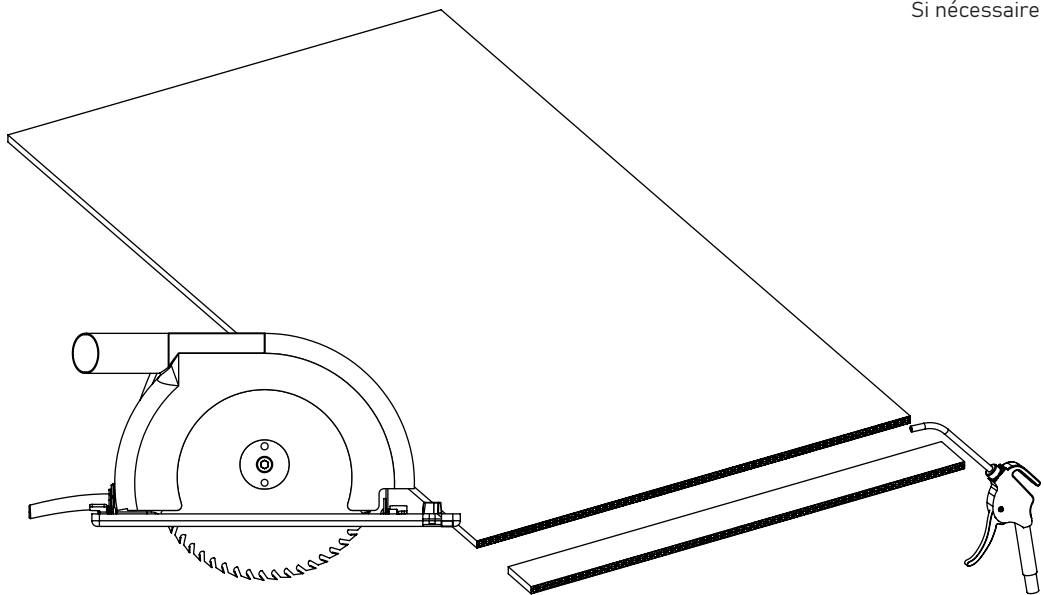

# 2

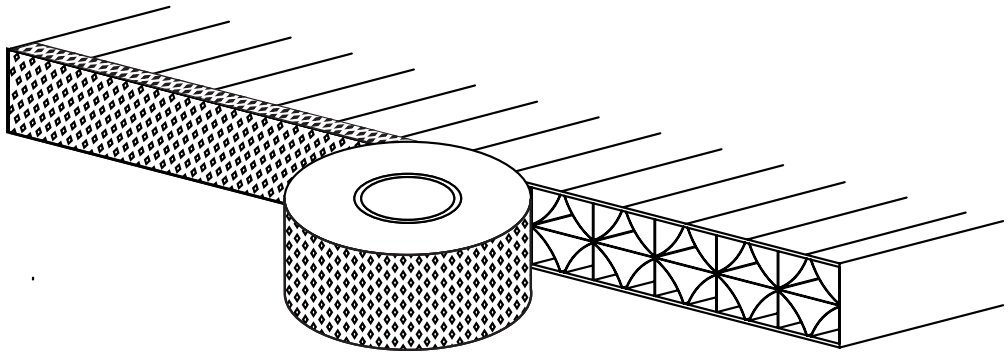
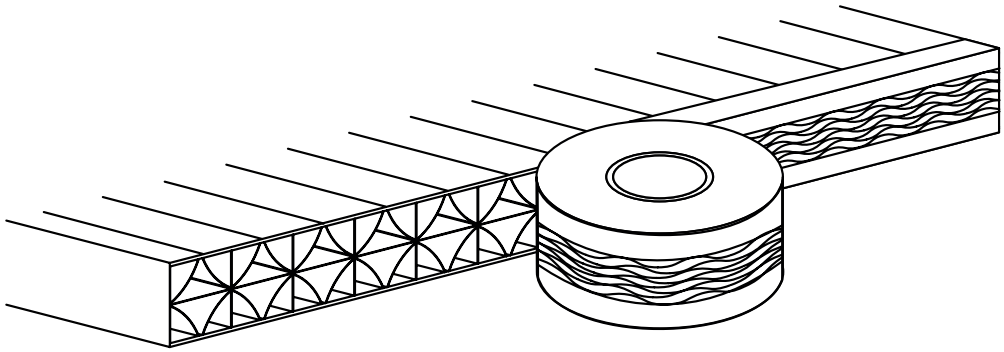

# 3

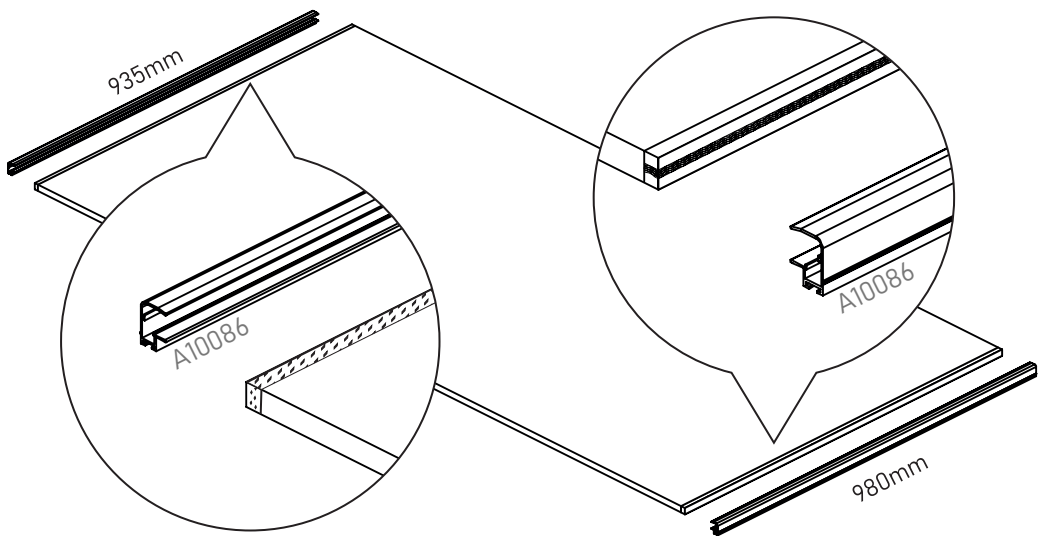

# 4

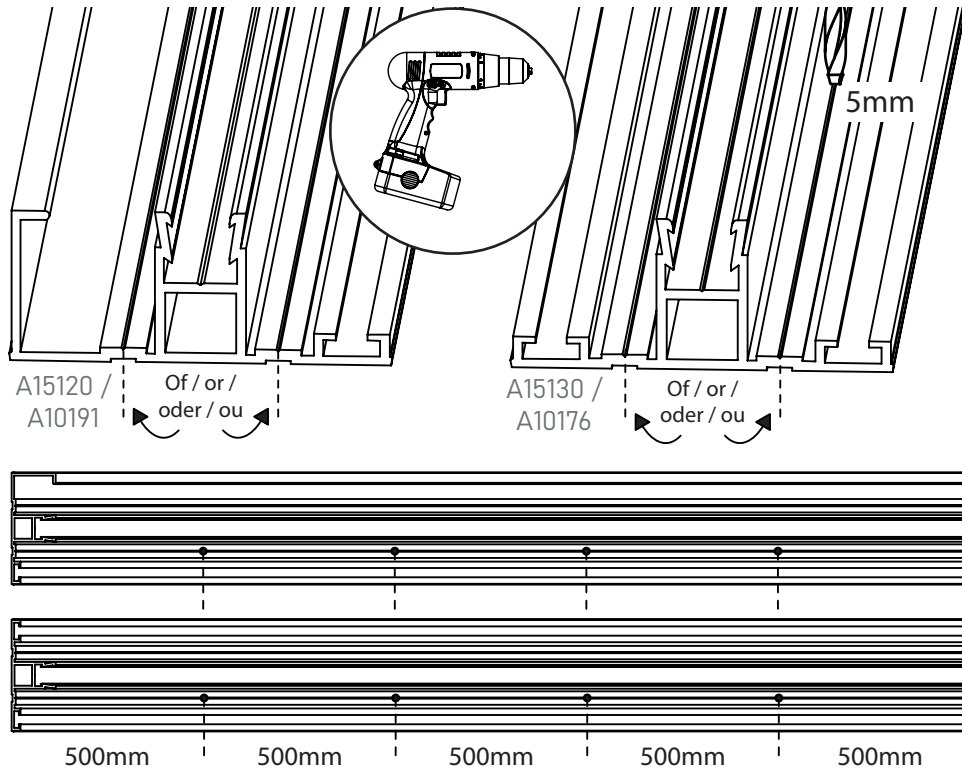

# 5

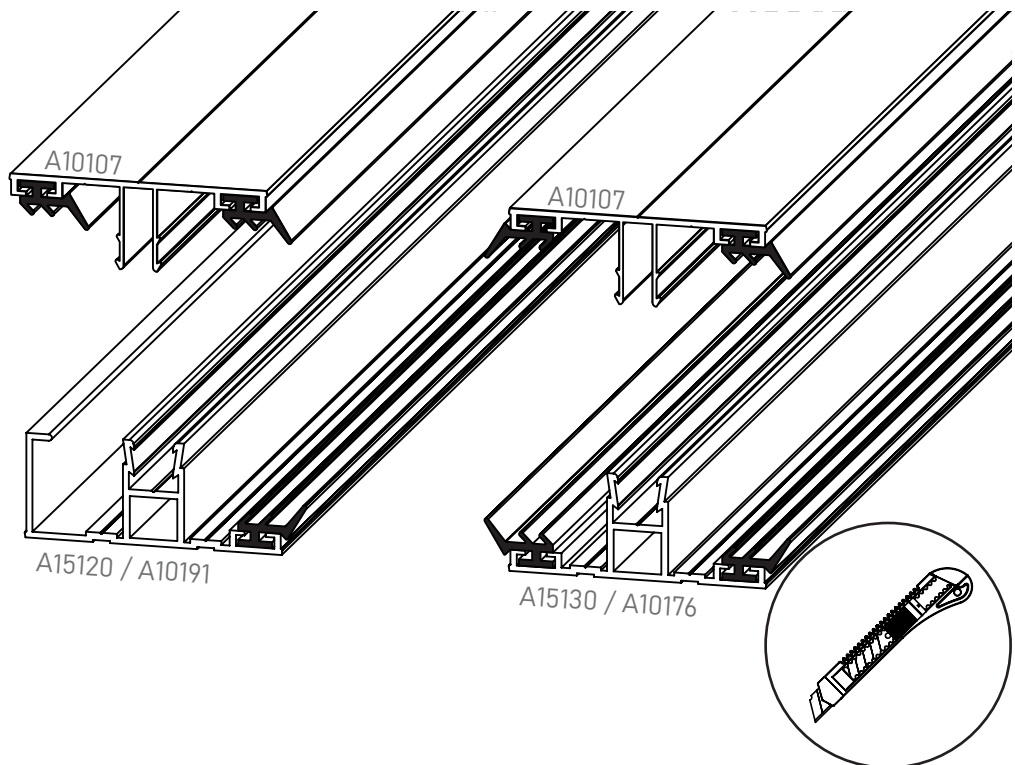

➔ step 12

6

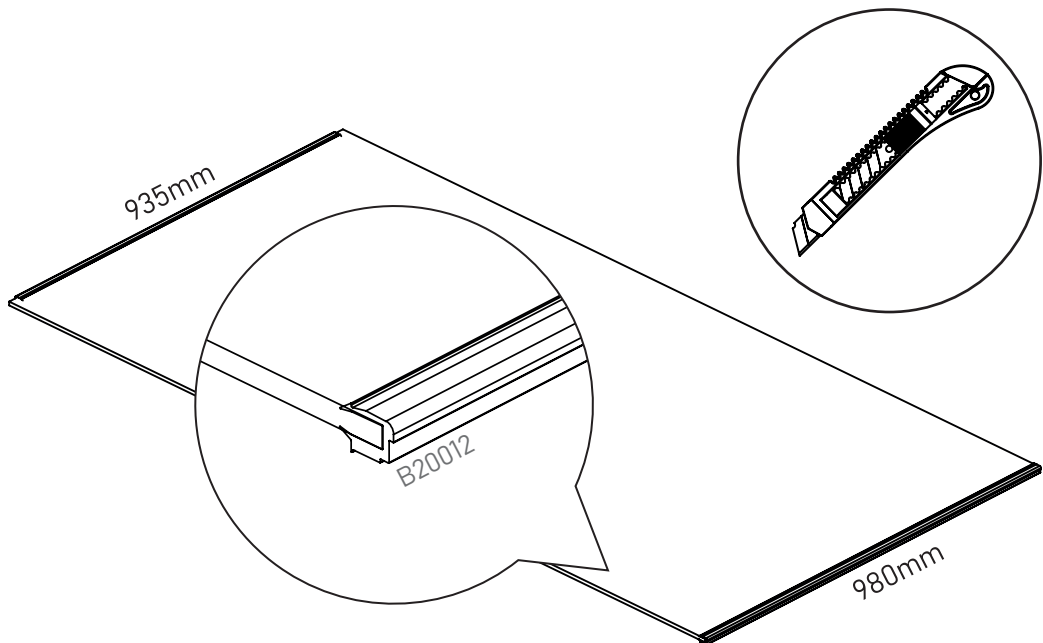

# 7

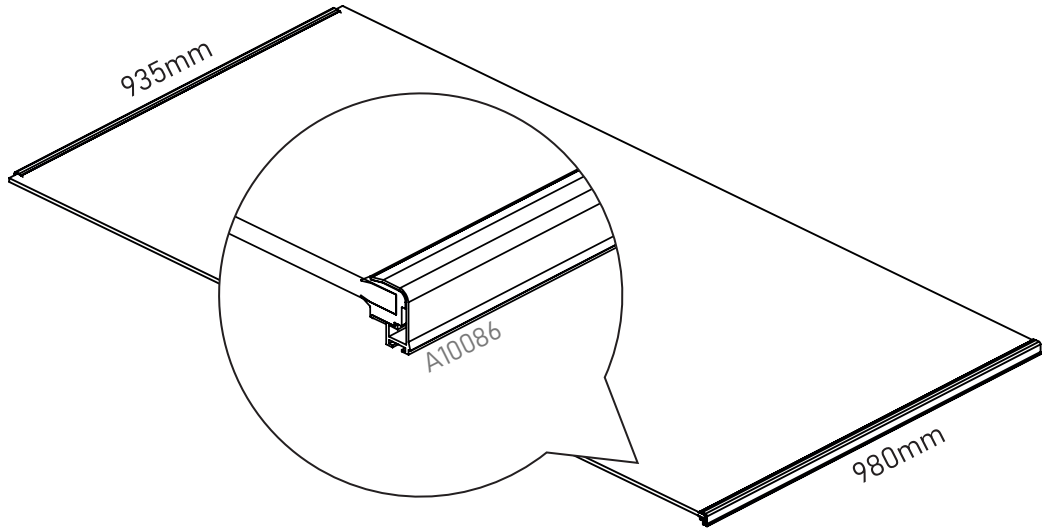

# 8

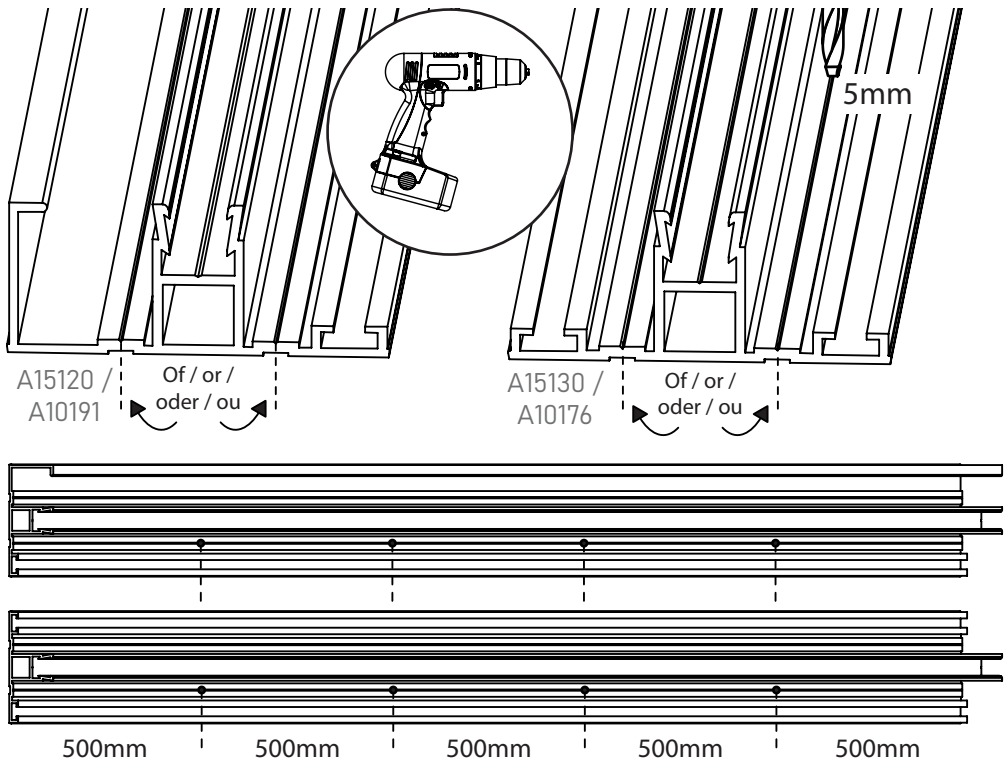

# 9

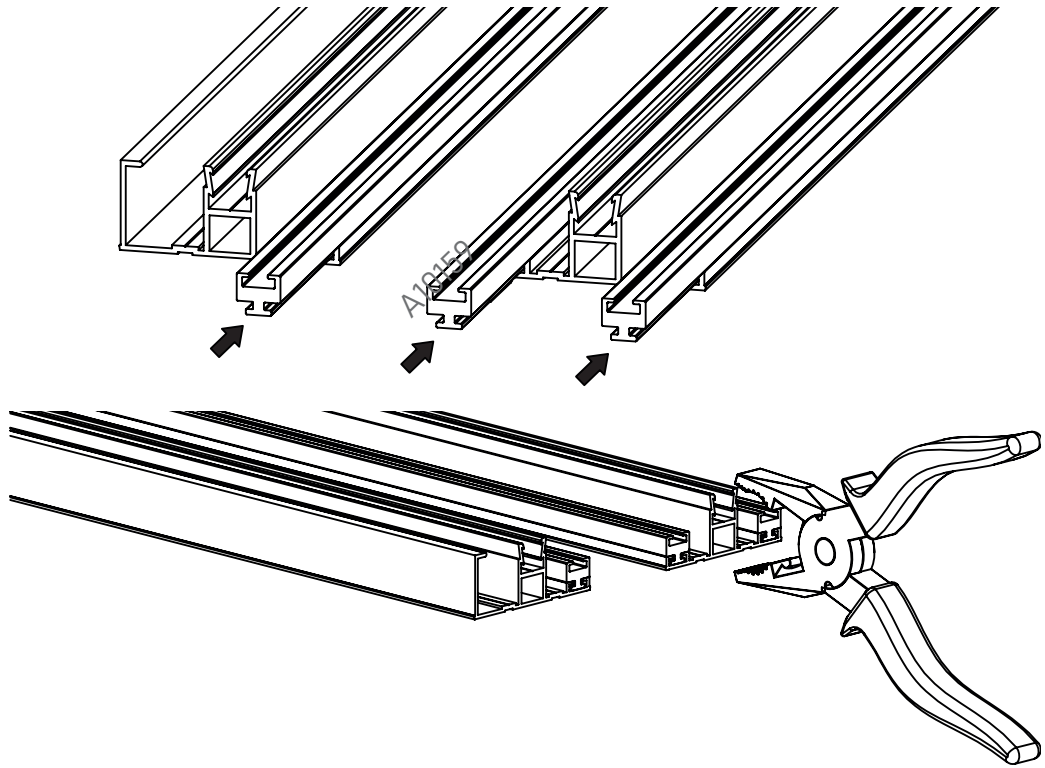

# 10

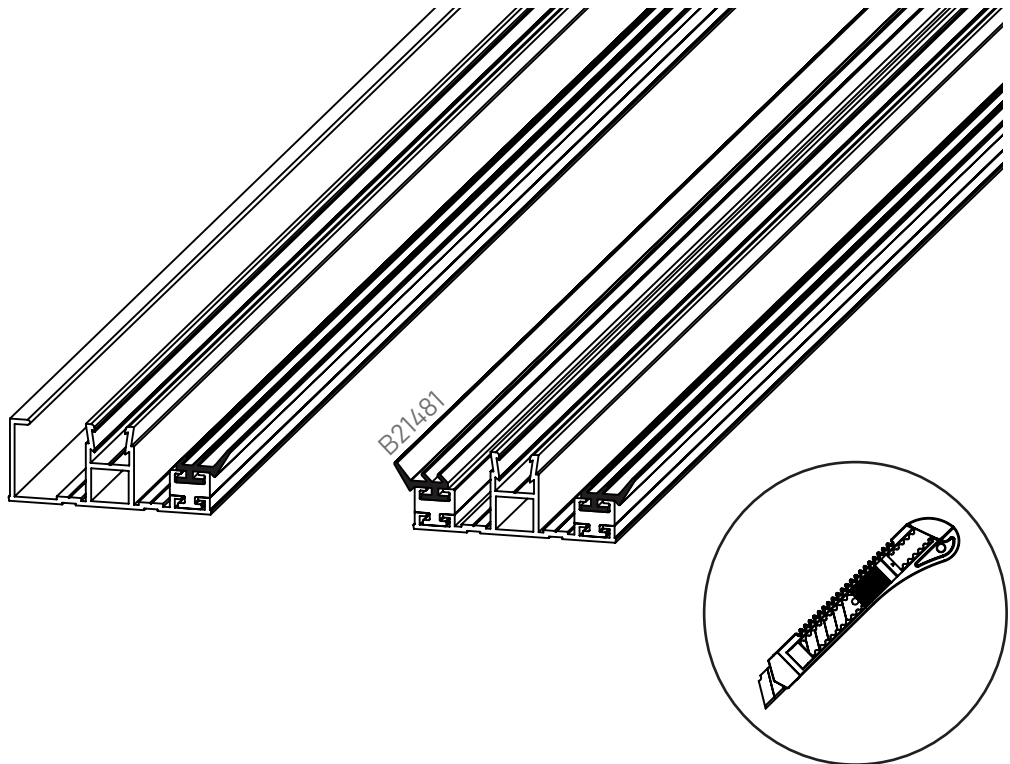

# 11

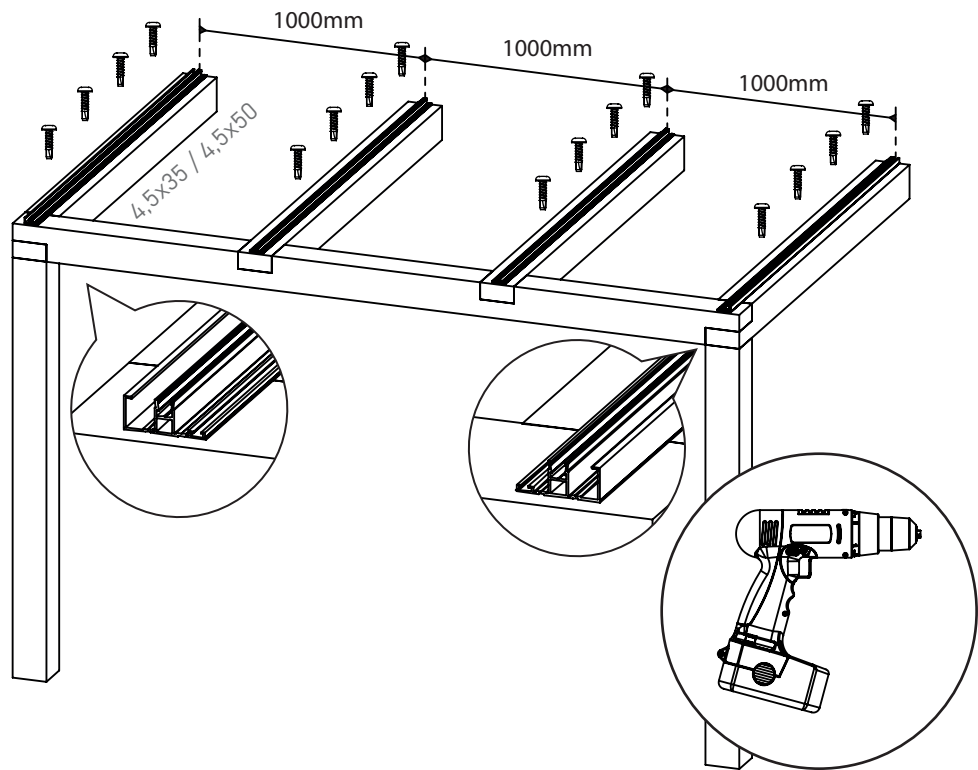

# 12

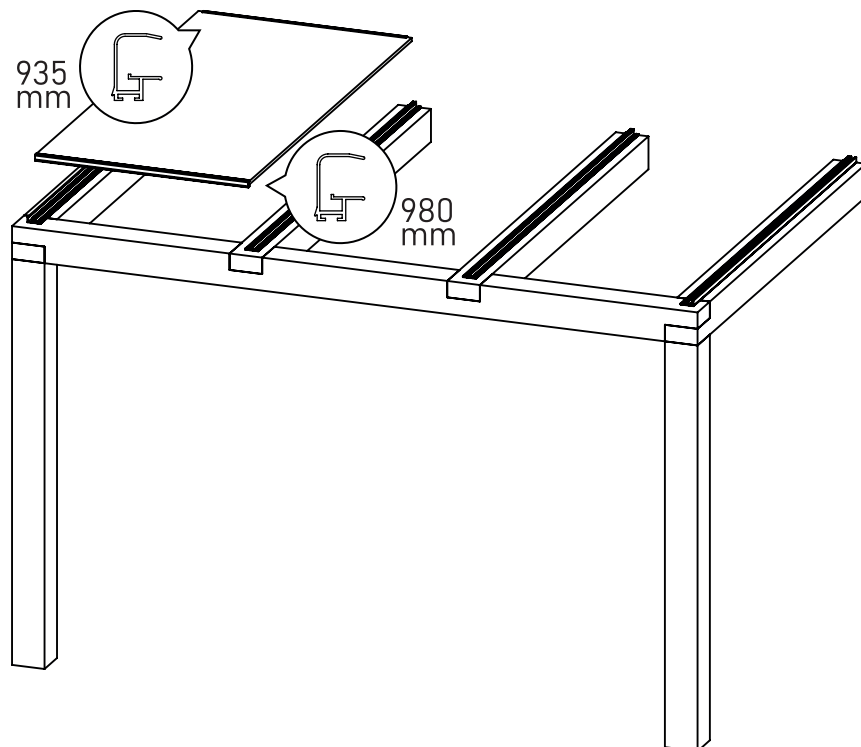

# 13

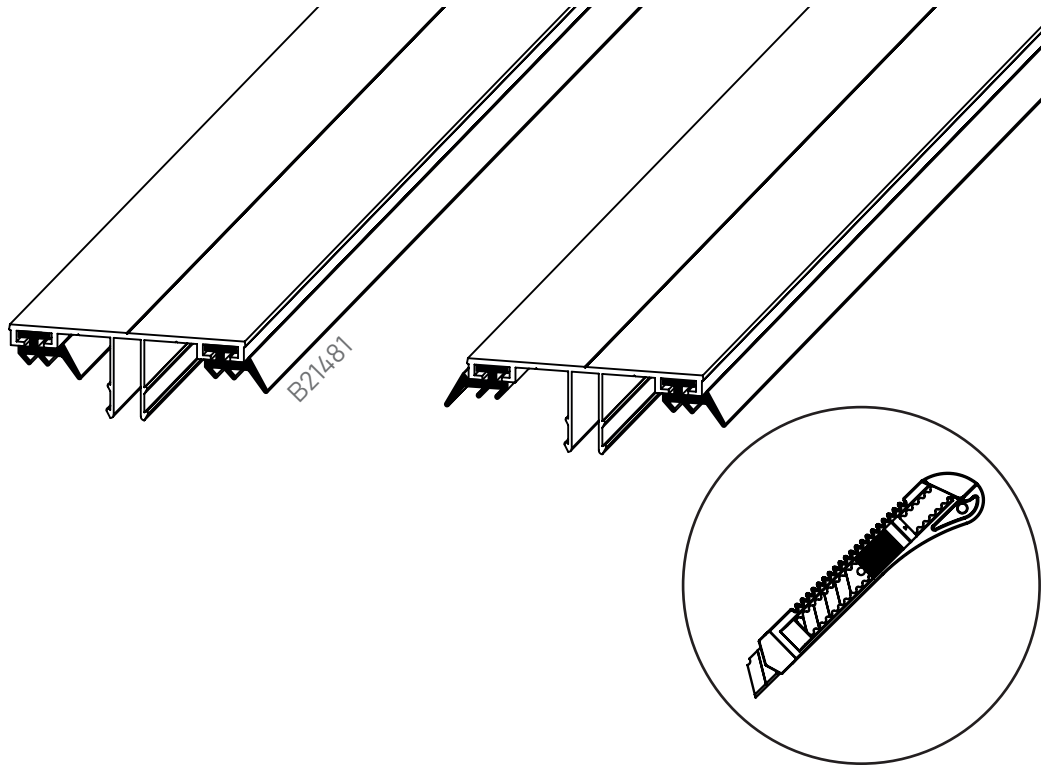

# 14

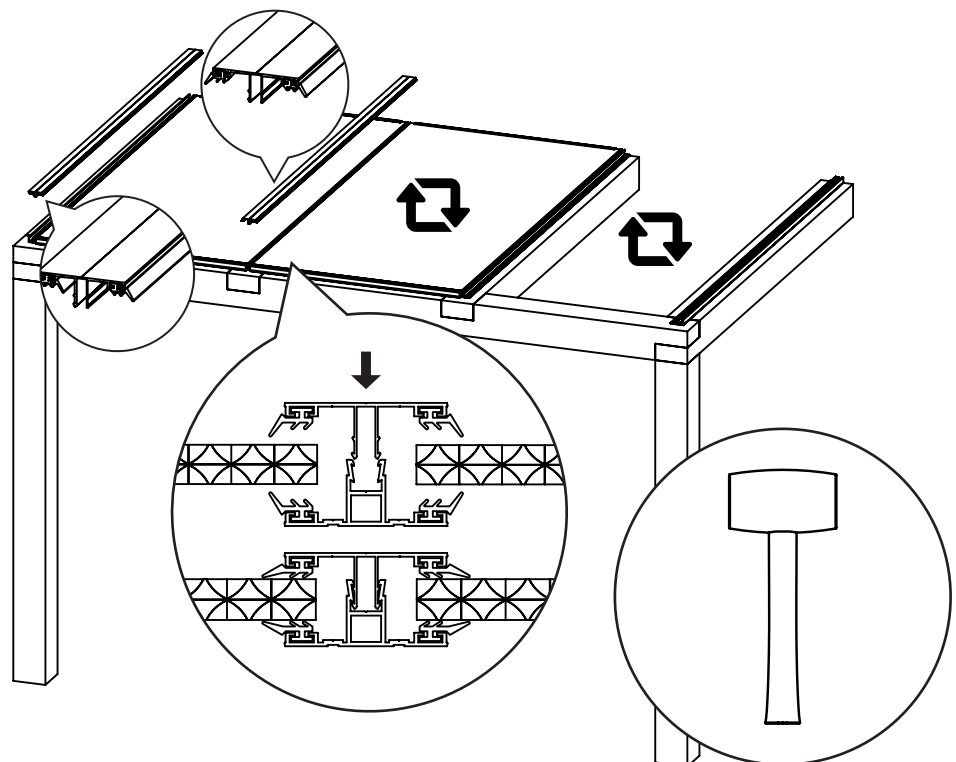



# 15

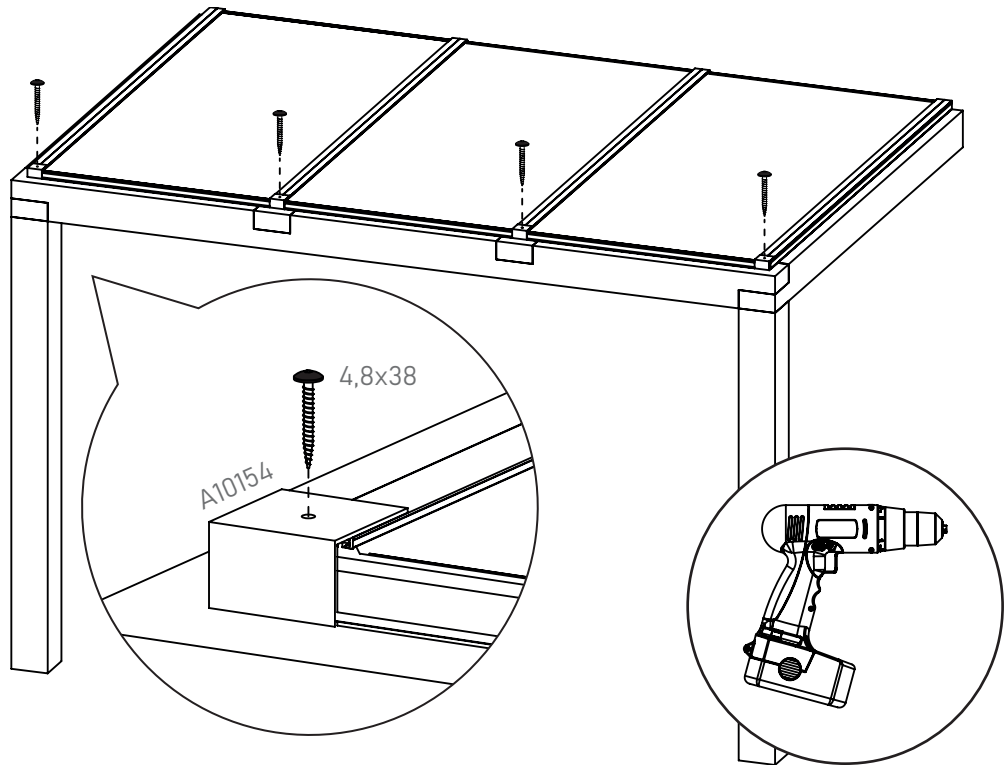

# 16

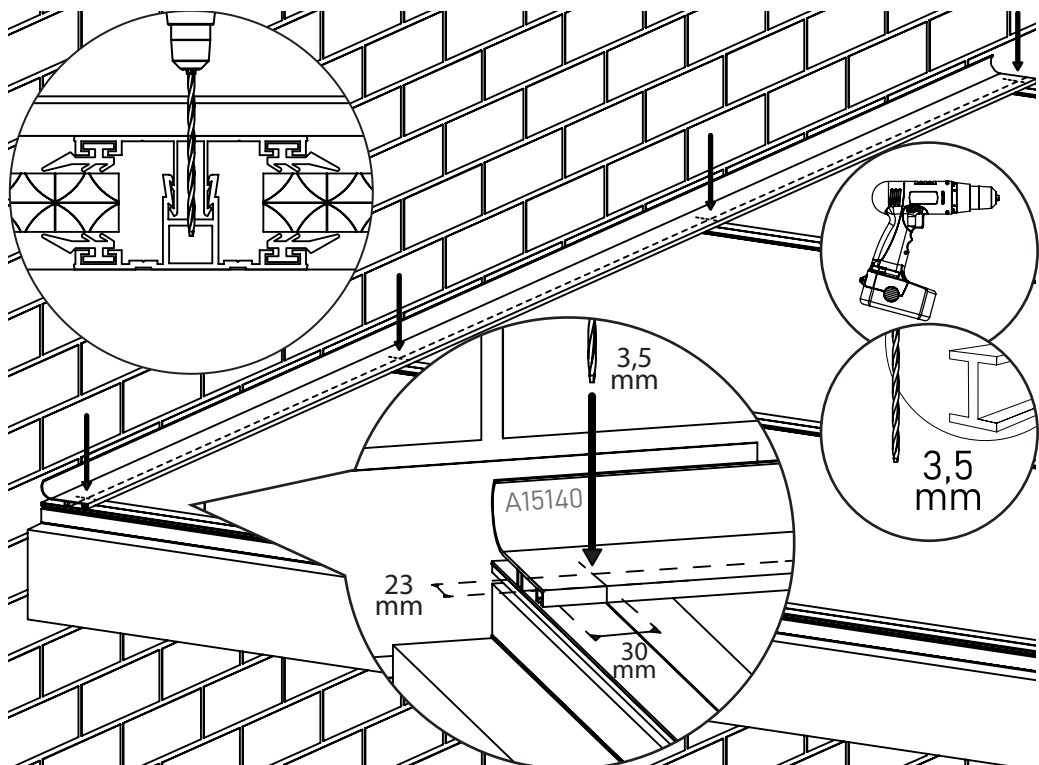

# 17

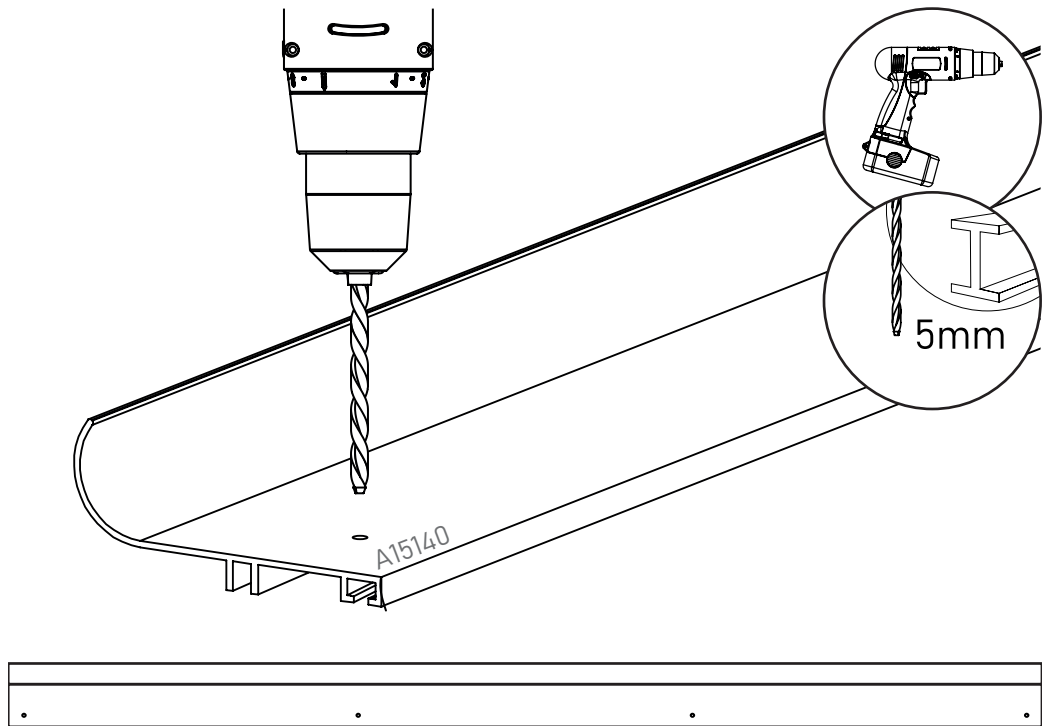

# 18

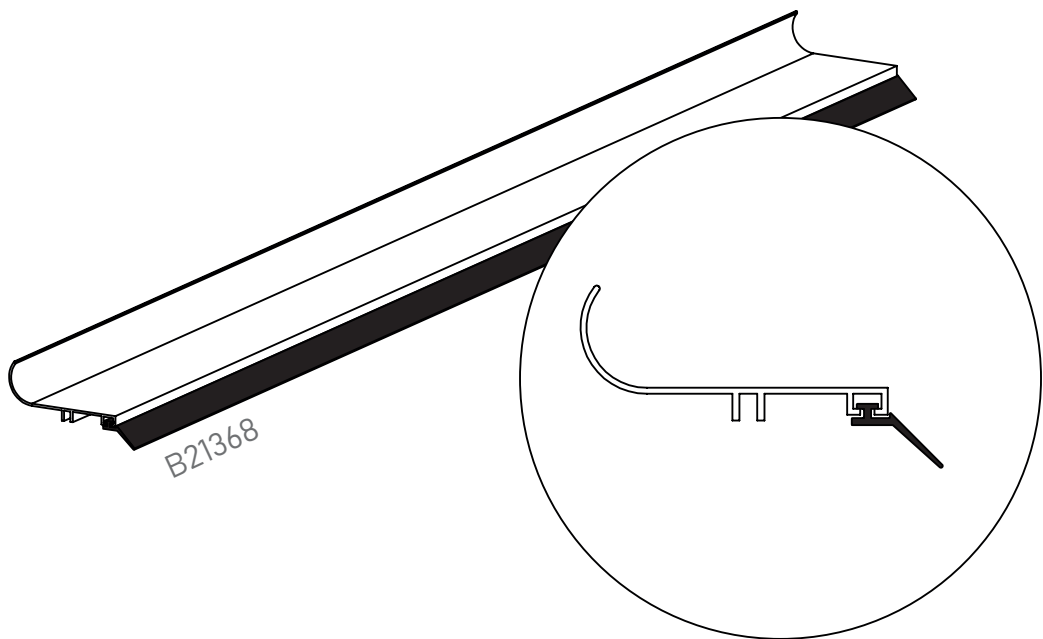

# 19

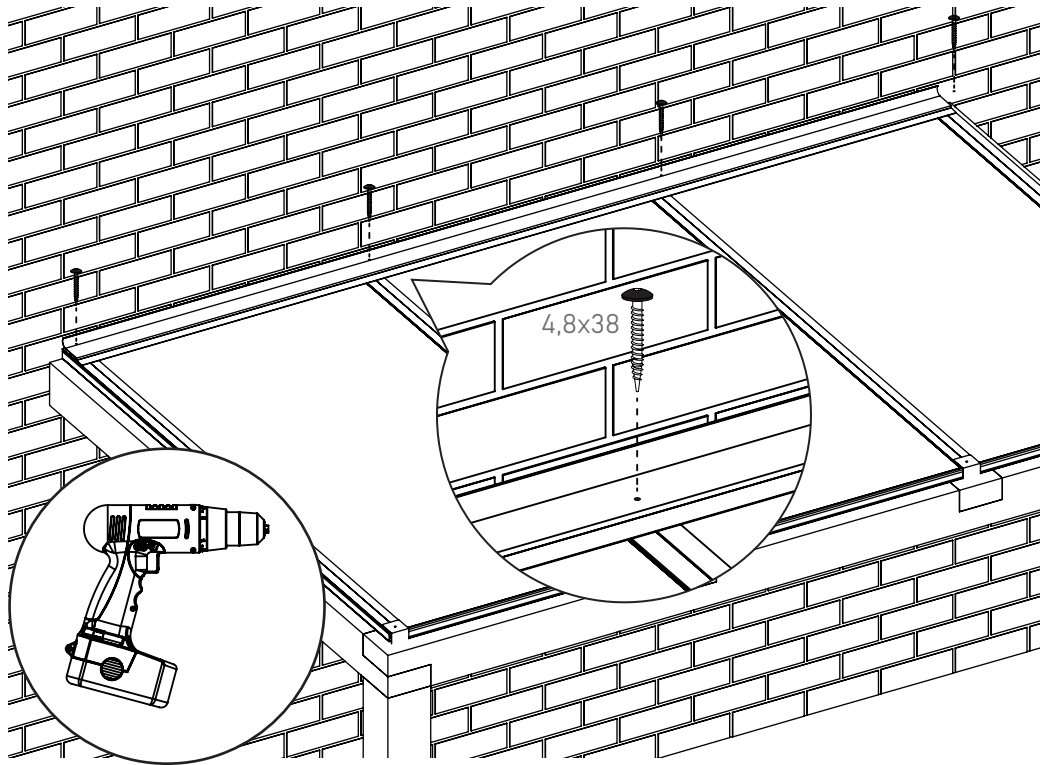

# 20

